

ITEM	STOCK CODE	QTY	DESCRIPTION
1	(#3210)	4	BS-KXHA HIGH SENSITIVITY SENSOR
2	(#3215)	1	KXP SENSOR FIXING PACK (NOT SHOWN)

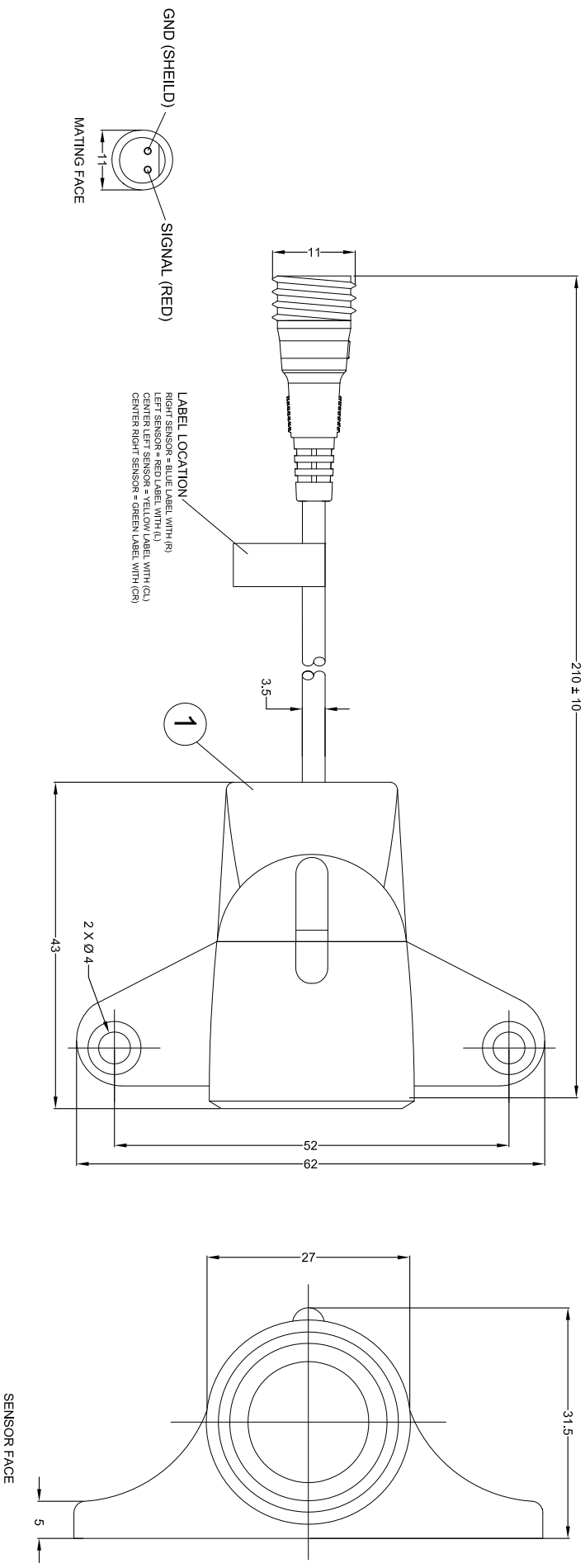

NOTES:  
 DIMENSIONS IN MM.  
 COLOUR: BLACK.  
 MODULE IS INTEGRATED INSIDE SENSOR HOUSING.  
 MATERIAL: SENSOR IS PLASTIC.  
 OPERATING FREQUENCY: 40KHz  
 CONNECTOR RATED IP67

PROPRIETARY NOTICE  
 THIS DESIGN AND TECHNICAL INFORMATION APPEARING ON THIS DRAWING IS THE PROPERTY OF BRIGADE ELECTRONICS PLC, AND IS DISCLOSED IN CONFIDENCE. IT IS NOT TO BE COPIED, REPRODUCED, REVEALED TO OR APPROPRIATE BY OTHERS, EITHER IN WHOLE OR IN PART WITHOUT THE EXPRESS WRITTEN CONSENT OF BRIGADE ELECTRONICS PLC.

ASSEMBLY PLANT REF: TBD

Item#	Quantity	Title/Name, designation, material, dimension etc	Article No./Reference
Designed by MOUTIER	Checked by ALAM	Approved by - date SMATTERS	Date 24/05/2010
BRIGADE ELECTRONICS		File name	Scale N/A
		BE-001066-00-10	Edition A
			Sheet 1/1